



**VMFLEX**

AUTOMAÇÃO E MANUTENÇÃO INDUSTRIAL

# ***CILINDROS ISO 6020/2***

***ISO 6020 CYLINDERS  
CILINDROS ISO 6020/2***

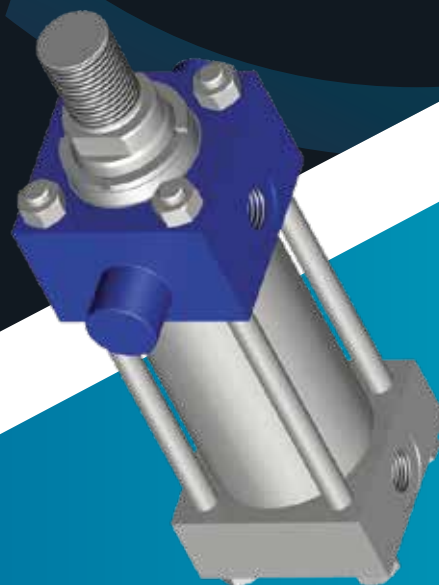

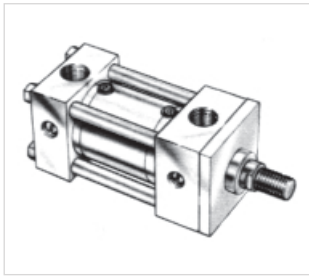

No Mount  
**NXM-MX5 - NXM-MX5D**

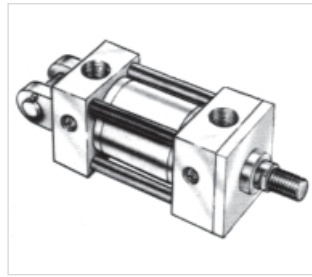

Cap fixed clevis  
**NXM-MP1**

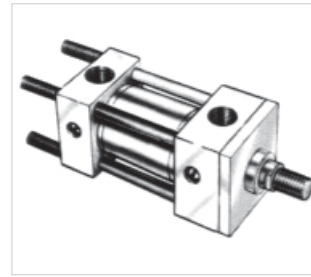

Cap end tie rods extended  
**NXM-MX2**

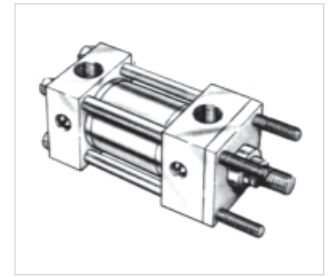

Head end tie rods extended  
**NXM-MX3 - NXM-MX3D**

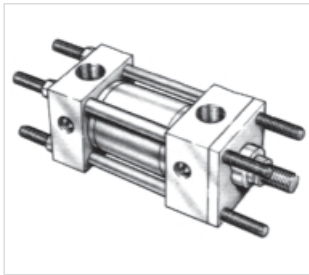

All tie rods extended  
**NXM-MX1 - NXM-MX1D**

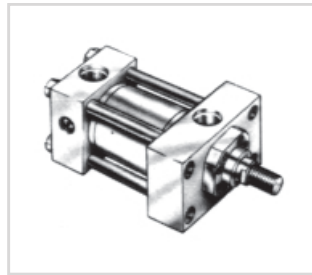

Head rectangular flange  
**NXM-ME5 - NXM-ME5D**

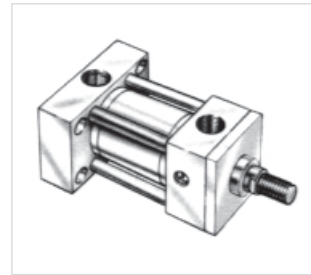

Cap rectangular flange  
**NXM-ME6**

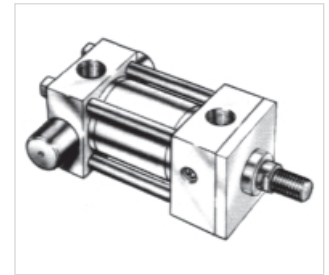

Cap trunnion  
**NXM-MT2**

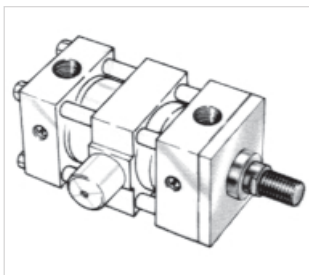

Intermediate fixed trunnion  
**NXM-MT4 - NXM-MT4D**

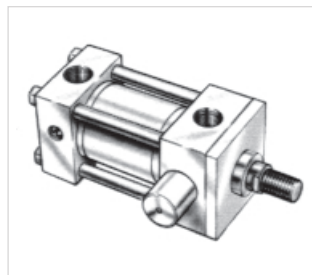

Head trunnion  
**NXM-MT1 - NXM-MT1D**

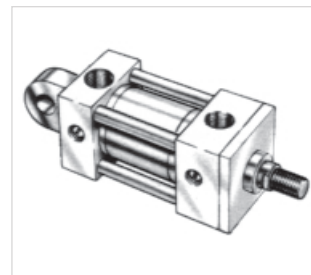

Cap eye  
**NXM-MP3**

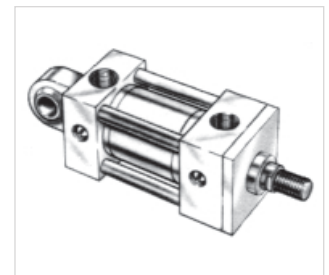

Cap spherical bearing  
**NXM-MP5**

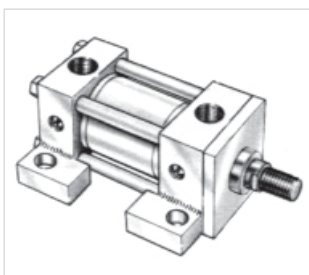

Piedini laterali  
**NXM-MS2-MS2DN**

#### MOUNTING INFORMATION

##### • Extended tie rod mountings

They are suitable for use on straight line forces and applications where mounting space is limited.

For compression-type applications (push) cap end tie rods extended type MX2 is recommended; head end tie rods extended MX3 is the most appropriate for tension-type applications (pull).

##### • Flange mounted cylinders

This type of mounting is suitable for use on straight line force transfer applications. Two mounting styles are available, with flanges at the head (ME5) or cap (ME6). ME6 is most appropriate for compression-type applications (push); ME5 should be used where the major load places the piston rod in tension (pull).

##### • Clevis mounted cylinders

Cylinders with this type of mounting, which absorb forces on their centre-line, should be used for applications where the item to be

moved travels in a curved path. They can be used for tension (pull) or compression (push) applications. Fixed cap clevis mounting cylinders MP1 and MP3 may be used if the curved path of the piston rod travels in a single plane; for applications where the piston rod will travel in a path either side of the true plane of motion, the spherical bearing mounting MP5 is highly recommended.

##### • Foot mounted cylinder

MS2 cylinders do not absorb force on their centre-lines. As a result, the application of force by the cylinder produces a turning moment which attempts to rotate the cylinder about its mounting bolts. It is therefore important for the cylinder to be firmly secured to the machine and for the load to be effectively guided.

##### • Trunnion mounted cylinder

Cylinders with this type of mounting (MT1, MT2 and MT4) are designed to absorb force on their centre-lines. They are suitable for tension (pull) or compression (push) applications, and may be used where the machine member to be moved travels in a curved path, in a single plane.

Trunnion pins are designed for shear loads only, and should be subject to minimum bending stresses.

## ISO 6020/2 HYDRAULIC CYLINDER

Each NEXOIL cylinder has a label with part number and description for easy identification

Please always refer to cylinder part number when ordering spare parts and seal kits

Features	ref.	Description	Example
<b>SERIES</b>	<b>NXM</b>	ISO 6020/2 cylinde 16 MPa - Chromed piston rod Honed tube	<b>NXM ME5 D X - 100 - 45 - M - 0.0 - L - AP - E1</b>
	<b>NXM</b>	ISO 6020/2 cylinder 15 MPa - Magnetic stainless steel piston Chromed piston rod, stainless steel honed tube (bore size 25 mm to 100 mm)	
<b>STANDARD MOUNTINGS</b>	<b>MX5</b>	Front tapped holes	
	<b>ME5</b>	Head rectangular flange	
	* <b>ME6</b>	Cap rectangular flange	
	* <b>MP1</b>	Cap fixed clevis	
	* <b>MP3</b>	Cap eye	
	* <b>MP5</b>	Cap spherical bearing	
	<b>MS2</b>	Side lugs	
	<b>MT1</b>	Head trunnion	
	* <b>MT2</b>	Cap trunnion	
	<b>MT4</b>	Intermediate fixed trunnion	
* mounting not available on double rod cylinders	<b>MX1</b>	All tie rods extended	
	<b>MX2</b>	Cap end tie rods extended	
	<b>MX3</b>	Head end tie rods extended	
<b>DOUBLE ROD</b>	<b>D</b>	Include ONLY for double-rod cylinder	
<b>SPECIAL MODIFICATIONS *</b> please include a drawing	<b>X</b>	Include ONLY if required	
	<b>Q</b>	Balancing cylinder	
<b>BORE</b>	-	Specify in mm	
<b>PISTON ROD DIAMETER</b>	-	Specify in mm	
<b>ROD END STYLE</b>	<b>M</b>	Male	
	<b>MY</b>	Male modified	
	<b>F</b>	Female	
	<b>FY</b>	Female modified	
<b>STROKE</b>	-	Specify in mm	
<b>SEALS</b>	<b>L*</b>	PISTON                      ROD Nitrile                      Polyurethane	
	<b>V</b>	Viton                              Viton	
	<b>BL</b>	Low-friction nitrile      Low-friction nitrile	
	<b>BV</b>	Low-friction viton        Low-friction viton	
<b>CUSHIONINGS</b>	<b>N</b>	No cushioning	
	<b>A</b>	Head end cushioning	
	<b>P</b>	Cap end cushioning	
	<b>AP</b>	Both ends cushioning	
<b>SERIAL NO.</b>	<b>E1</b>	To be always indicated	

### Specifications

- Heavy duty metric hydraulic cylinder
- Nominal pressure: 160 bar
- In accordance with ISO 6020/2 (1991), DIN 24554 standards
- Security factor 4:1 at nominal pressure and with reference to min. breaking point
- Hydraulic mineral oil - other fluids available upon request
- Temperature range for standard seals: from -20°C to +80°C
- Construction: tie-rod design
- Bore sizes: 25 mm to 200 mm
- Piston rod diameters: 12 mm to 140 mm
- Cushions: adjustable and available on either or both ends (non-adjustable cushionings on bore size 25)
- Special modifications to customer's requirements

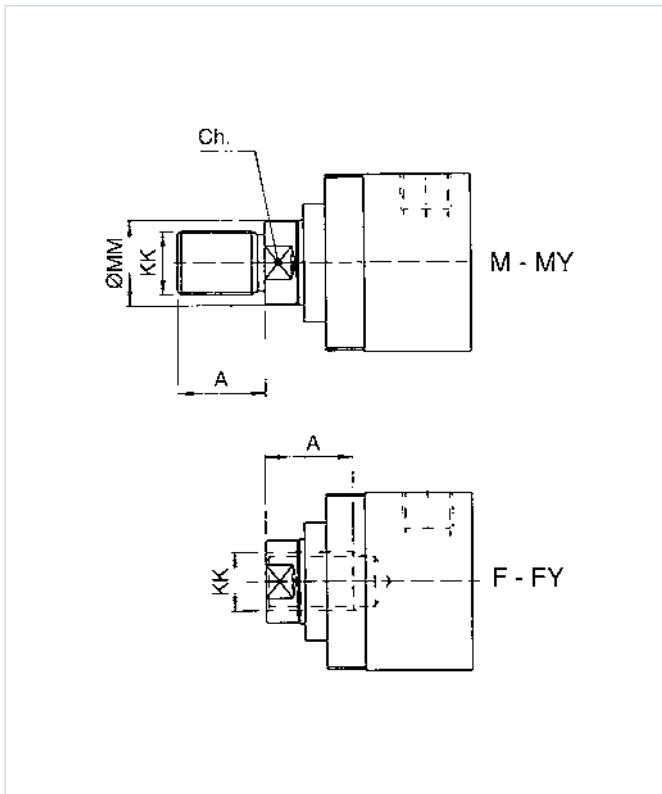

(\*) Female rod thread variants:

- F 25-12: M 8 x 1  
 FY 25-18: M12 x 1,25  
 F 32-14: M10 x 1,25  
 F 40-18: M12 x 1,25

Bore	rod MM	Type M-F*		Type MY-FY*		
		KK	A	KK	A	Ch
25	12	M10x1.25	14			10
	18	M14x1.5	18	M10x1.25	14	1 5
32	14	M12x1.25	16			12
	22	M16x1.5	22	M12x1.25	16	19
40	18	M14x1.5	18			15
	28	M20x1.5	28	M14 x1.5	18	2 4
50	22	M16x1.5	22			19
	**28	M20x1.5	28			24
63	36	M27x2	36	M16 x1.5	22	32
	28	M20x1.5	28			24
80	**36	M27x2	36			32
	45	M33x2	45	M20 x1.5	28	4 0
100	36	M27x2	36			32
	**45	M33x2	45			40
125	56	M42x2	5 6	M27x2	36	5 0
	45	M33x2	45			40
160	**56	M42x2	56			50
	70	M48x2	63	M33x2	45	6 0
200	56	M42x2	56			50
	**70	M48x2	63			60
250	90	M64x3	85	M42 x2	56	80
	70	M48x2	63			60
315	**90	M64x3	85			80
	110	M80x3	95	M48x2	63	100
400	90	M64x3	85			80
	**110	M80x3	95			100
500	140	M100x3	130	M64x3	85	130

\* Rod diam. no. 3 do not conform to ISO standard

### Port & cushion adjustment screw location

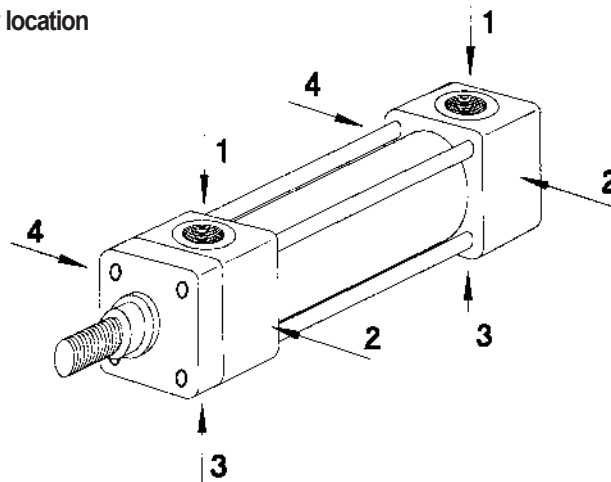

Bore	Ports	Oversize ports	Port location	Cushion adjustment screw location (according to mounting)	
				MX5-MS2-MP1 MP3-MP5	ME5-ME6 MT1-MT2
25	G 1/4"	G 3/8"	1	not available	not available
32	G 1/4"	G 3/8"	1	2	2
40	G 3/8"	G 1/2"	1	2	3
50	G 1/2"	G 3/4"	1	2	3
63	G 1/2"	G 3/4"	1	2	3
80	G 3/4"	G 1"	1	2	3
100	G 3/4"	G 1"	1	2	3
125	G 1"	G 1.1/4"	1	2	3
160	G 1"	G 1.1/4"	1	2	3
200	G 1.1/4"	G 1.1/2"	1	2	3

Front tapped holes - MX5

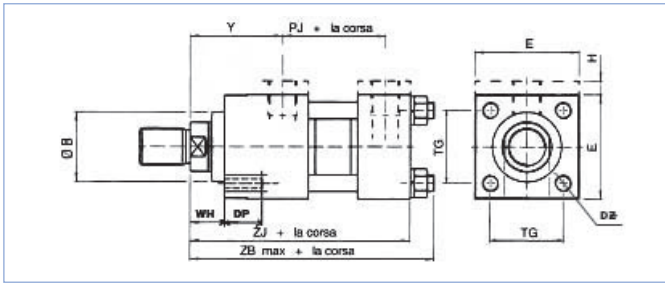

Head rectangular flange - ME5

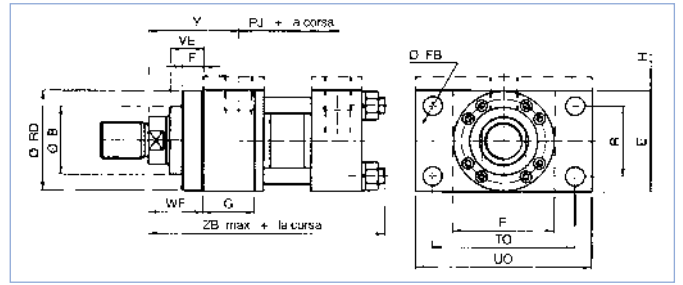

Cap rectangular flange - ME6

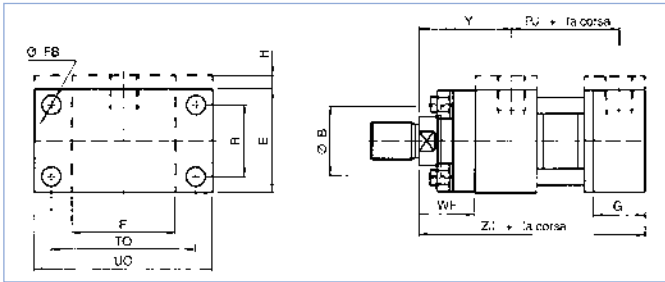

Cap fixed clevis - MP1

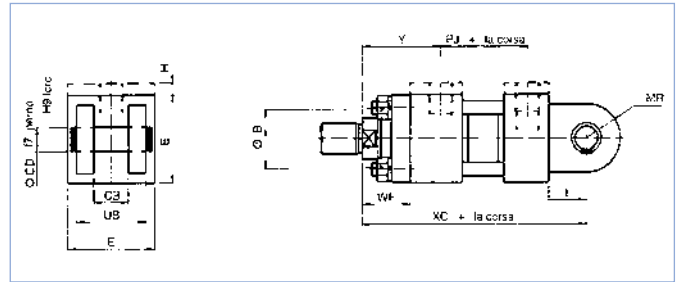

Cap eye - MP3

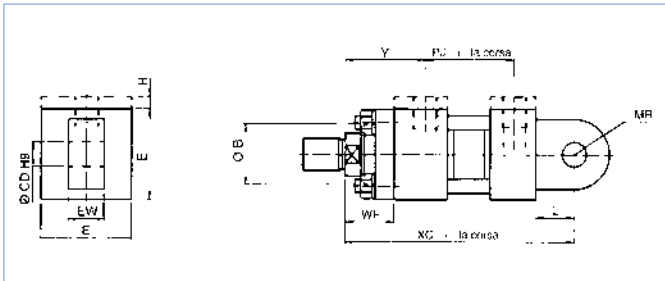

Side lugs - MS2

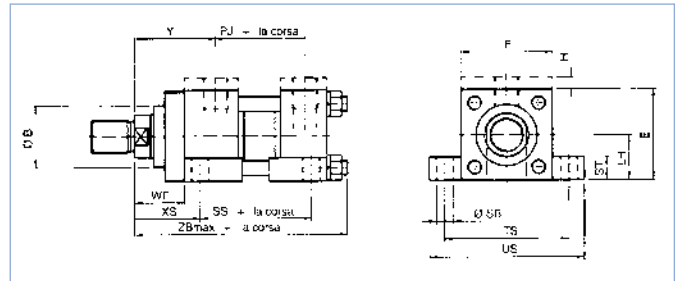

Cap spherical bearing - MP5

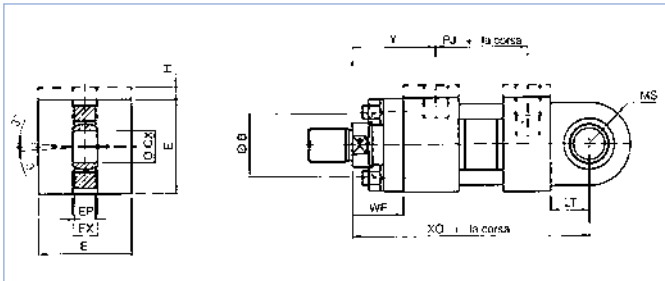

Head trunnion - MT1

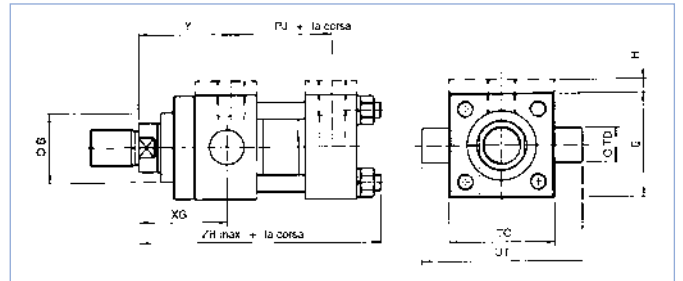

Cap trunnion - MT2

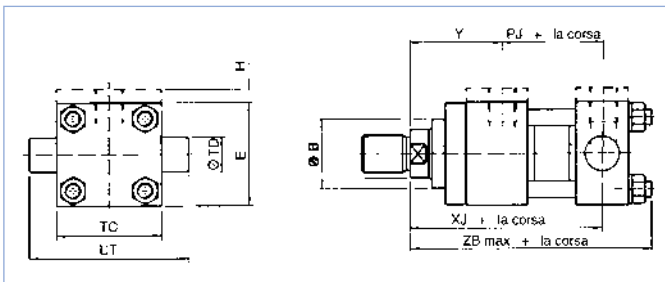

Intermediate fixed trunnion - MT4

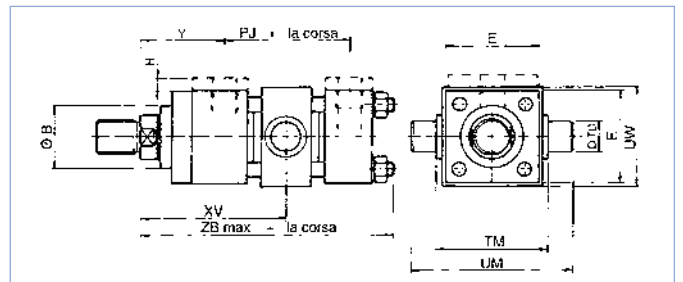

Head end tie rods extended - MX3

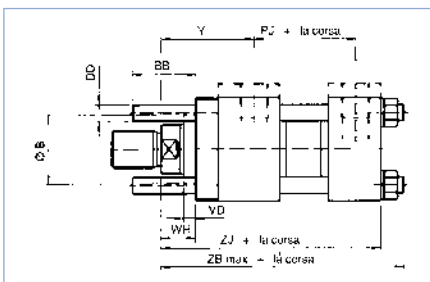

Cap end tie rods extended - MX2

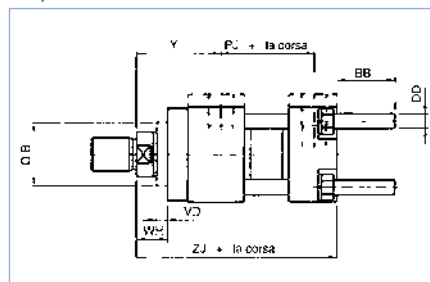

All tie rods extended - MX1

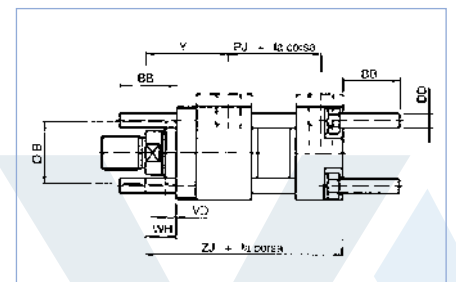

Bore	Ø Rod	B	BB	CB A16	CD Toll.	CX	DD	E	EP	EW h14	EX	F	FB	G	H	L	LH h10	LT	MR	MS	PJ	R	RD f8	SB	SS
25	12	24	19	12	10	12 <sup>-0.008</sup>	M5x0.8	40	8	12	10	10	5.5	25	5	13	19	16	12	20	53	27	38	6.6	73
	18	30																							
32	14	26	24	16	12	16 <sup>-0.008</sup>	M6x1	45	11	16	14	10	6.6	25	5	19	22	20	17	22.5	56	33	42	9	73
	22	34																							
40	18	30	35	20	14	20 <sup>-0.012</sup>	M8x1	63	13	20	16	10	11	38		19	31	25	17	29	73	41	62	11	98
	28	42																							
50	22	34	46	30	20	25 <sup>-0.012</sup>	M12x1.25	75	17	30	20	16	14	38		32	37	31	29	33	74	52	74	14	92
	36	50																							
63	28	42	46	30	20	30 <sup>-0.012</sup>	M12x1.25	90	19	30	22	16	14	38		32	44	38	29	40	80	65	75	18	86
	45	60																					88		
80	36	50	59	40	28	40 <sup>-0.012</sup>	M16x1.5	115	23	40	28	20	18	45		39	57	48	34	50	93	83	82	18	105
	56	72																					105		
100	45	60	59	50	36	50 <sup>-0.012</sup>	M16x1.5	130	30	50	35	22	18	45		54	63	58	50	62	101	97	92	26	102
	70	88																					125		
125	56	72	81	60	45	60 <sup>-0.015</sup>	M22x1.5	165	38	60	44	22	22	58		57	82	72	53	80	117	126	105	26	131
	90	108																					150		
160	70	88	92	70	56	80 <sup>-0.015</sup>	M27x2	205	47	70	55	25	26	58		63	101	92	59	100	130	155	125	33	130
	110	133																					170		
200	90	108	115	80	70	100 <sup>-0.020</sup>	M30x2	245	57	80	70	25	33	76		82	122	116	82	120	165	190	150	39	172
	140	163																					210		
	110	133	FLFL																				210		

Bore	Ø Rod	ST	TC	TD f8	TG	TM	TO	TS	UB	UM	UO	US	UT	UW <input type="checkbox"/>	VD	VE	WF	WH	XC	XG	XJ	XO	XS	XV MIN	XV MAX	Y	ZB	ZJ	min. stroke for mounting MT4	
25	12	8.5	38	12	28.3	48	51	54	24	68	65	72	58	48	6	16	25	15	127	44	101	130	33	82	72	50	121	114	10	
	18																							+ stroke						
32	14	12.5	44	16	33.2	55	58	63	32	79	70	84	68	55	12	22	35	25	147	54	115	148	45	96	82	60	137	128	14	
	22																							+ stroke						
40	18	12.5	63	20	41.7	76	87	83	40	108	110	103	95	76	12	22	35	25	172	57	134	178	45	107	88	62	166	153	19	
	28																							+ stroke						
50	22	19	76	25	52.3	89	105	102	60	129	130	127	116	89	9	25	41	25	191	64	140	190	54	117	90	67	176	159	27	
	36																							+ stroke						
63	28	26	89	32	64.3	100	117	124	60	150	145	161	139	100	13	29	48	32	200	70	149	206	65	132	91	71	185	168	41	
	45																							+ stroke						
80	36	26	114	40	82.7	127	149	149	80	191	180	186	178	127	9	29	51	31	229	76	168	238	68	147	99	77	212	190	48	
	56																							+ stroke						
100	45	32	127	50	96.9	140	162	172	100	220	200	216	207	140	10	32	57	35	257	71	187	261	79	158	107	82	225	203	51	
	70																							+ stroke						
125	56	32	165	63	125.9	178	208	210	120	278	250	254	265	178	10	32	57	35	289	75	209	304	79	180	109	86	260	232	71	
	90																							+ stroke						
160	70	38	203	80	154.9	215	253	260	140	341	300	318	329	215	7	32	57	32	308	75	230	337	86	198	104	86	279	245	94	
	110																							+ stroke						
200	90	44	241	100	190.2	279	300	311	160	439	360	381	401	279	7	32	57	32	381	85	276	415	92	226	130	98	336	299	96	
	140																							+ stroke						
	110																													

See above chart for minimum stroke for MT4 mounting.

XV dimension is always to be specified when ordering a cylinder with MT4 mounting. The value must be between minimum XV and maximum XV + stroke

All tie rods extended - MX1D

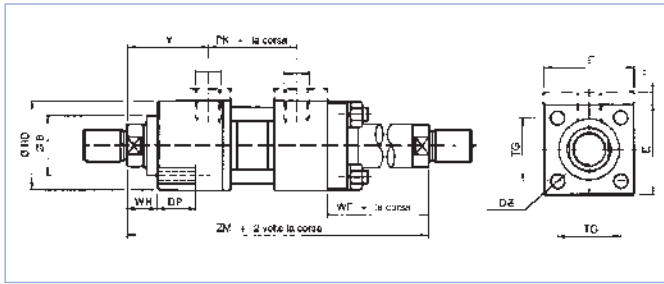

Head rectangular flange - ME5D

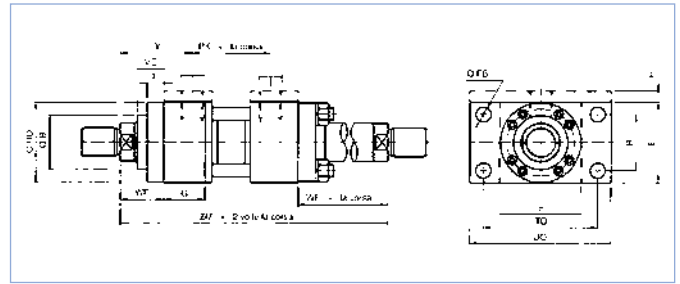

Head trunnion - MT1D

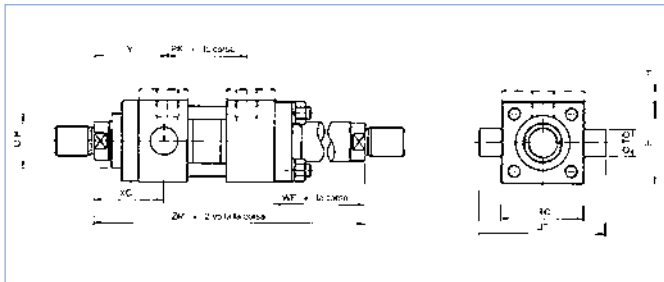

Intermediate fixed trunnion - MT4D

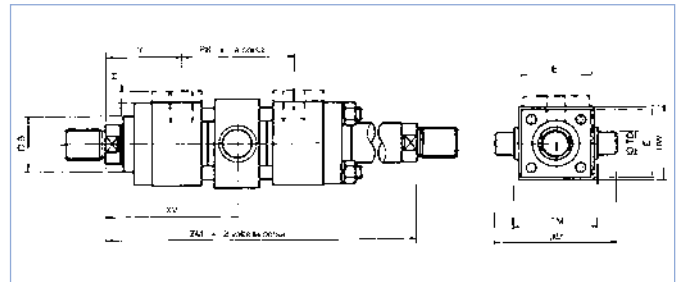

Side lugs - MS2D

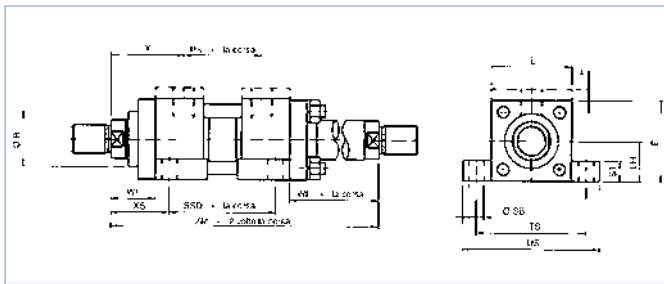

Head end tie rods extended - MX3D

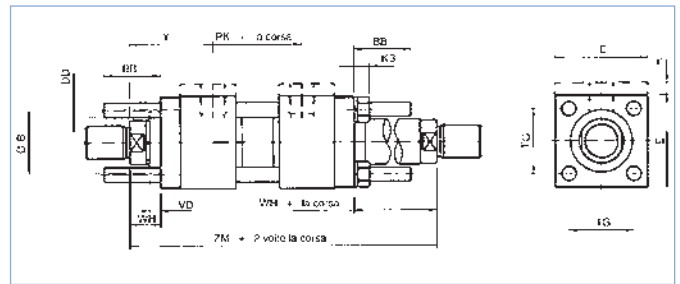

Bore	Ø	B	BB	DD	E	F	FB	G	H	KB	LH	PK	R	RD	SB	SSD	ST	TC	TD	TG	TM	TO	TS	UM	UO	US	UT	UW	VD	VE	WF	WH	XG	XS	XV	XV	Y	ZM	minim. mounting stroke MT4D	
	rod										h10			Ø8					Ø8														min	max						
25	12	24	19	M5x0,8	40	10	5,5	25	5	5,2	19	54	27	38	6,6	88	8,5	38	12	28,3	48	51	54	68	65	72	58	48	6	16	25	15	44	33	82	72	50	154	10	
	18	30																																						
32	14	26	24	M6x1	45	10	6,6	25	5	6,6	22	58	33	42	9	88	12,5	44	16	33,2	55	58	63	79	70	84	68	55	12	22	35	25	54	45	96	82	60	178	14	
	22	34																																						
40	18	30	35	M8x1	63	10	11	38		8,5	31	71	41	62	11	105	12,5	63	20	41,7	76	87	83	108	110	103	95	76	12	22	35	25	57	45	107	88	62	195	19	
	28	42																																						
50	22	34	46	M12x1,25	75	16	14	38		12,5	37	73	52	74	14	99	19	76	25	52,3	89	105	102	129	130	127	116	89	9	25	41	25	64	54	117	90	67	207	27	
	36	50																																						
63	28	42	46	M12x1,25	90	16	14	38		12,5	44	81	65	75	18	93	26	89	32	64,3	100	117	124	150	145	161	139	100	13	29	48	32	70	65	132	91	71	223	41	
	45	60																																						
80	56	50	59	M16x1,5	115	20	18	45		16,5	57	92	83	82	18	110	26	114	40	82,7	127	149	149	191	180	186	178	127	9	29	51	31	76	68	147	99	77	246	48	
	56	72																																						
100	45	60	59	M16x1,5	130	22	18	45		16,5	63	101	97	92	26	107	32	127	50	96,9	140	162	172	220	200	216	207	140	10	32	57	35	71	79	158	107	82	265	51	
	70	88																																						
125	56	72	81	M22x1,5	165	22	22	58		22	82	117	126	105	26	131	32	165	63	125,9	178	208	210	278	250	254	265	178	10	32	57	35	75	79	180	109	86	289	71	
	90	108																																						
160	70	88	92	M27x2	205	25	26	58		27	101	130	155	125	33	130	38	203	80	154,9	215	253	260	341	300	318	329	215	7	32	57	32	75	86	198	104	86	302	84	
	110	133																																						
200	90	108	115	M30x2	245	25	33	76		30	122	160	190	150	39	172	44	241	100	190,2	279	300	311	439	360	381	401	279	7	32	57	32	85	92	226	130	98	356	96	
	140	163																																						
	110	133																																						

See above chart for minimum stroke for MT4 mounting  
 dimension is always to be specified when ordering a cylinder with MT4 mounting. The value must be between minimum XV and maximum XV + stroke XV

## Femal clevis ISO 6982 (pivot pin not included)

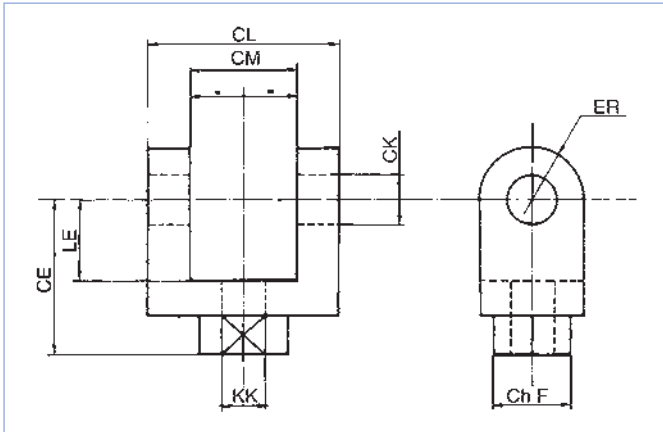

Part number	CM	CKH9	CE	CL	ChF	KK	LE	ER
CF-H-10125	12	10	32	26	19	10x1,25	13	12
CF-H-12125	16	12	36	34	21	12x1,25	19	17
CF-H-1415	20	14	38	42	21	14x1,5	19	17
CF-H-1615	30	20	54	62	32	16x1,5	32	29
CF-H-2015	30	20	60	62	32	20x1,5	32	29
CF-H-272	40	28	75	83	40	27x2	39	34
CF-H-332	50	36	99	103	56	33x2	54	50
CF-H-422	60	45	113	123	56	42x2	57	53
CF-H-482	70	56	126	143	75	48x2	63	59
CF-H-643	80	70	168	163	95	64x3	83	78
CF-H-803	80	70	168	163	95	80x3	83	78
CF-H-1003	100	100	250	230	160	100x3	90	95

## Pivot pin

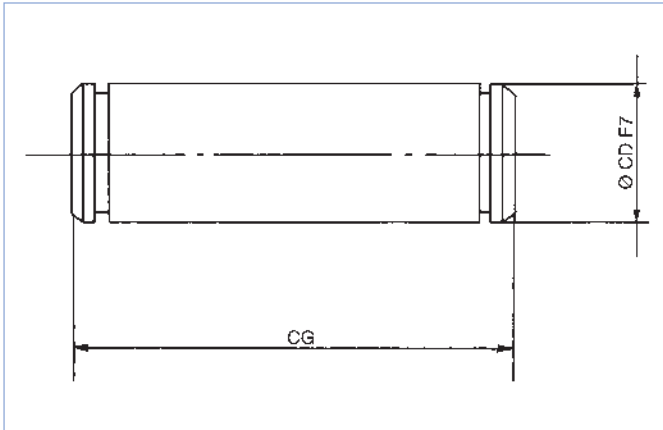

Part number	CD	CG
2.44.01.37.95	10	32
2.44.05.37.95	12	40
2.44.10.37.95	14	50
2.44.15.37.95	20	70
2.44.25.37.95	28	92
2.44.30.37.95	36	114
2.44.35.37.95	45	135
2.44.40.37.95	56	158
2.44.45.37.95	70	180

## Spherical rod eye ISO 6982

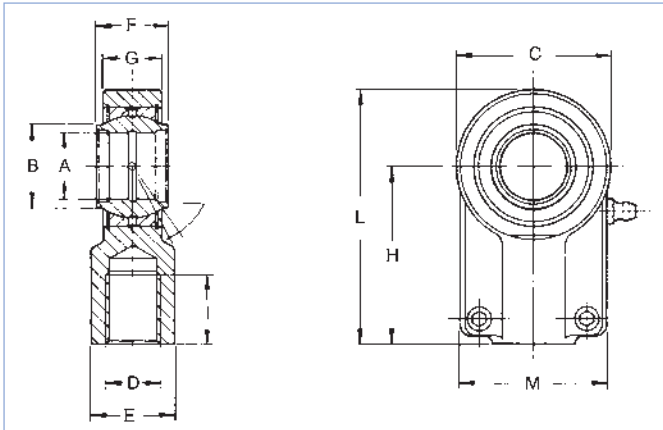

Type	A	B	C	D	E	F	G	H	I	L	M	Stat. load	Din. load
TAPR	H7					h12							
10CE	10	12,5	32	M10x1,25	15	10	7	37	14	53	32	20	8,15
12CE	12	15,5	32	M12x1,25	16	12	10,5	38	17	54	32	24,5	10,8
16CE	16	20	40	M14x1,5	21	16	13	44	19	64	40	36,5	17,8
20CE	20	25	47	M16x1,5	25	20	17	52	23	77	47	48	30
25CE	25	30,5	58	M20x1,5	30	25	21	65	29	96	54	78	48
32CE	32	38	70	M27x2	38	32	27	80	37	118	66	114	67
40CE	40	46	89	M33x2	47	40	32	97	46	145,5	80	114	67
50CE	50	57	108	M42x2	58	50	40	120	57	179	96	310	156
63CE	63	71,5	132	M48x2	70	63	52	140	64	211	114	430	255
80CE	80	91	168	M64x3	90	80	66	180	86	270	148	695	400
100CE	100	113	210	M80x3	110	100	84	210	96	322	178	1060	610
125CE	125	138	264	M100x3	135	125	102	260	113	405	200	3650	2120

## Self-aligning rod end coupler

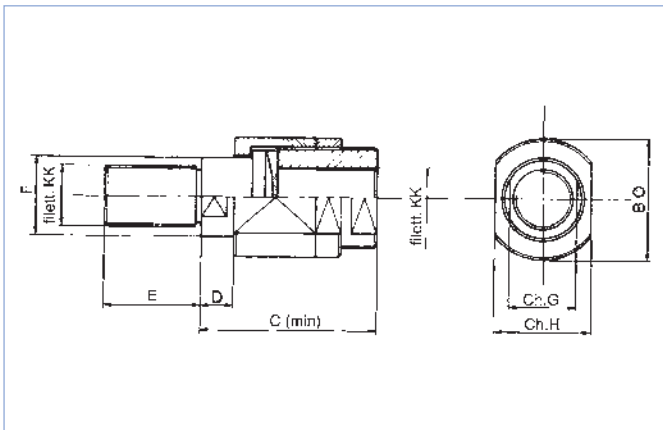

Part number	B	C	D	E	F	chG	chH	KK
AUT-H-10125	31,7	50,8	12,7	19	15,9	14	20	10x1,25
AUT-H-12125	31,7	50,8	12,7	19	15,9	14	20	12x1,25
AUT-H-1415	42,8	58,7	12,7	28,5	24,6	22	28	14x1,5
AUT-H-1615	42,8	58,7	12,7	28,5	24,6	22	28	16x1,5
AUT-H-2015	42,8	58,7	12,7	28,5	24,6	22	28	20x1,5
AUT-H-272	57	73,8	12,7	41	34,1	30	42	27x2
AUT-332	66,6	91,8	19	51	43,6	38	50	33x2
AUT-H-422	76,2	105,5	22,2	57	50	44	60	42x2
AUT-482	95,2	138,1	25,4	76	62,7	54	76	48x2
AUT-H-643	127	163,5	25,4	89	88,1	76	102	64x3
AUT-H-803	184	238,1	25,4	140	138,9	*	146	80x3
AUT-H-1003	184	238,1	25,4	140	138,9	*	146	100x3

\* No 4 spanner holes at 90° instead of flats



Eye bracket

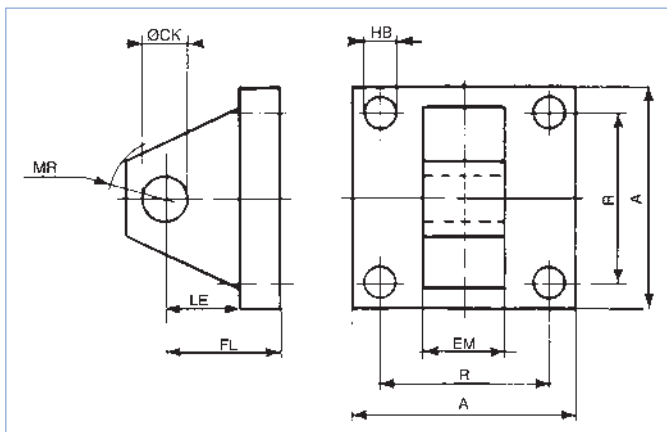

Part number	A	R	EM h13	HB	CKH9	MR <sub>max</sub>	LE <sub>min</sub>	FL
CCM-H-10	40	28,3	12	5,5	10	12	13	23
CCM-H-12	45	33,2	16	6,6	12	17	19	29
CCM-H-14	65	41,7	20	9	14	17	19	29
CCM-H-20	75	52,3	30	13,5	20	29	32	48
CCM-H-20-A	90	64,3	30	13,5	20	29	32	48
CCM-H-28	115	82,7	40	17,5	28	34	39	59
CCM-H-36	130	96,9	50	17,5	36	50	54	79
CCM-H-45	165	125,9	60	26	45	53	57	87
CCM-H-56	205	154,9	70	30	56	59	63	103
CCM-H-70	240	190,2	80	33	70	78	82	132

Female eye

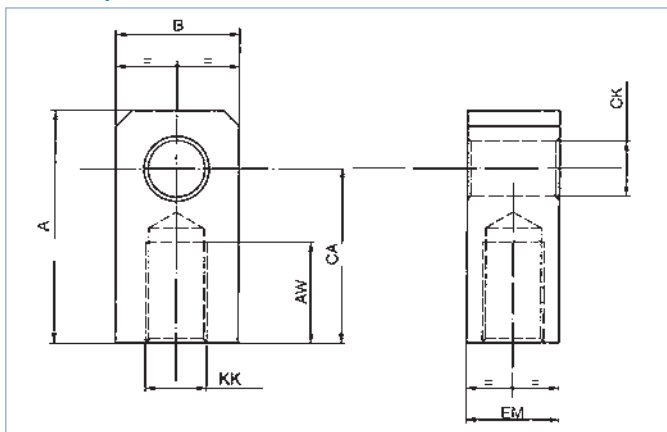

Part number	A	B	EM	CKH9	CA	AW	KK
CM-H-10125	44	20	12	10	32	14	10x1,25
CM-H-12125	53	24	16	12	36	16	12x1,25
CM-H-1415	55	28	20	14	38	18	14x1,5
CM-H-1615	83	40	30	20	54	22	16x1,5
CM-H-2015	89	40	30	20	60	28	20x1,5
CM-H-272	109	56	40	28	75	36	27x2
CM-H-332	149	72	50	36	99	45	33x2
CM-H-422	166	90	60	45	113	56	42x2
CM-H-482	185	112	70	56	126	63	48x2
CM-H-643	246	140	80	70	168	85	64x3
CM-H-803	246	140	80	70	168	95	80x3
CM-H-1003	345	200	100	100	250	112	100x3

Female clevis ISO 8133 (pivot pin included)

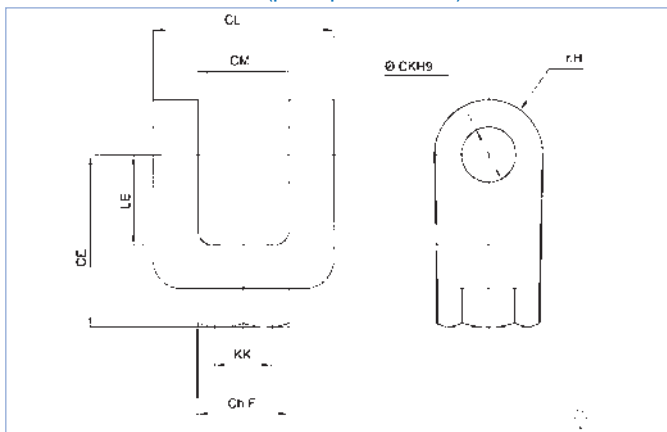

Part number	CM	KK	CL	CE	LE	CK (H9)	Ch.F	r.H
260CF1310	12	M10x1,25	24	32	13	10	19	12
260CF1312	16	M12x1,25	32	36	19	12	21	17
260CF1314	20	M14x1,5	40	38	19	14	21	17
260CF1316	30	M16x1,5	60	54	32	20	32	29
260CF1320	30	M20x1,5	60	60	32	20	32	29
260CF1327	40	M27x2	80	75	39	28	40	34
260CF1333	50	M33x3	100	99	54	36	56	50
260CF1342	60	M42x2	120	113	57	45	56	53
260CF1348	70	M48x2	140	126	63	56	75	59
260CF1364	80	M64x3	160	168	83	70	95	78
260CF1380	80	M80x3	160	168	83	70	95	78

Spherical rod eye ISO 8133

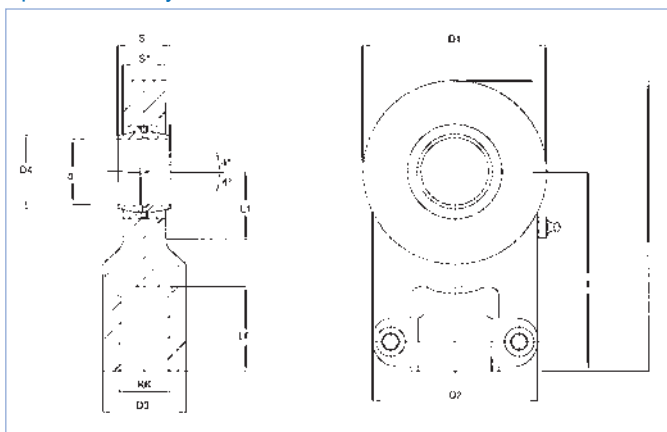

Part number	d	S	D4	I	D1	D2	S1	L	L1	D3	LF	KK
290TAPR12S	12	10	15	42	35	40	8	58	16	17	15	M10x1,25
290TAPR16S	16	14	20,7	48	45	45	11	69	20	21	17	M12x1,25
290TAPR20S	20	16	24,1	58	55	55	13	83	28	25	19	M14x1,5
290TAPR25S	25	20	29,3	68	65	62	17	99	31	30	23	M16x1,5
290TAPR30S	30	22	34,2	85	80	77	19	123	35	36	29	M20x1,5
290TAPR40S	40	28	45	105	100	90	23	153	45	45	37	M27x2
290TAPR50S	50	35	56	130	120	105	30	188	58	55	46	M33x3
290TAPR60S	60	44	66,8	150	160	134	38	255	68	68	55	M42x2
290TAPR80S	80	55	89,4	185	205	156	47	282,5	82	90	64	M48x2
290TAPR100S	100	70	109,5	240	240	190	55	357,5	116	110	86	M64x3



ASSISTÊNCIA 24 HORAS

PORTO:  
**229 698 040**

LISBOA:  
**215 817 952**



**OPORTO**  
Zona Industrial Alto de Vilar  
R. Bouça dos Estilhadouros, 306/314  
4445-044 **ALFENA** • Portugal  
Tlf. +351 229 698 040 • Fax. +351 220 100 362  
[geral@vmflex.pt](mailto:geral@vmflex.pt)

**LISBOA**  
Parque Industrial do Seixal  
R. Rodrigo Sarmento de Beires, Lote 13, Arm 2  
2840-068 **ALDEIA DE PAIO PIRES** • Portugal  
Tlf. +351 215 817 952  
[lisboa@vmflex.pt](mailto:lisboa@vmflex.pt)